

THIS DRAWING IS UNPUBLISHED. RELEASED FOR PUBLICATION, 19 .
 © COPYRIGHT 19 BY AMP INCORPORATED. ALL RIGHTS RESERVED.

| LOC | DIST | REVISIONS | | | |
|-----|------|-------------|--------------------|---------|-------|
| P | LTR | DESCRIPTION | DATE | DWN | APVD |
| G | 14 | C | REV / 0720-0967-96 | 09SEP96 | ME TM |

| | | |
|--------------------------------|--------------------------------|--------------------------------|
| AMP WIRE RANGE | UL E13288 | SP LR7189 Certified |
| 12-10 AWG SOLID OR STRANDED | 12-10 AWG SOLID OR STRANDED | 12-10 AWG SOLID OR STRANDED |

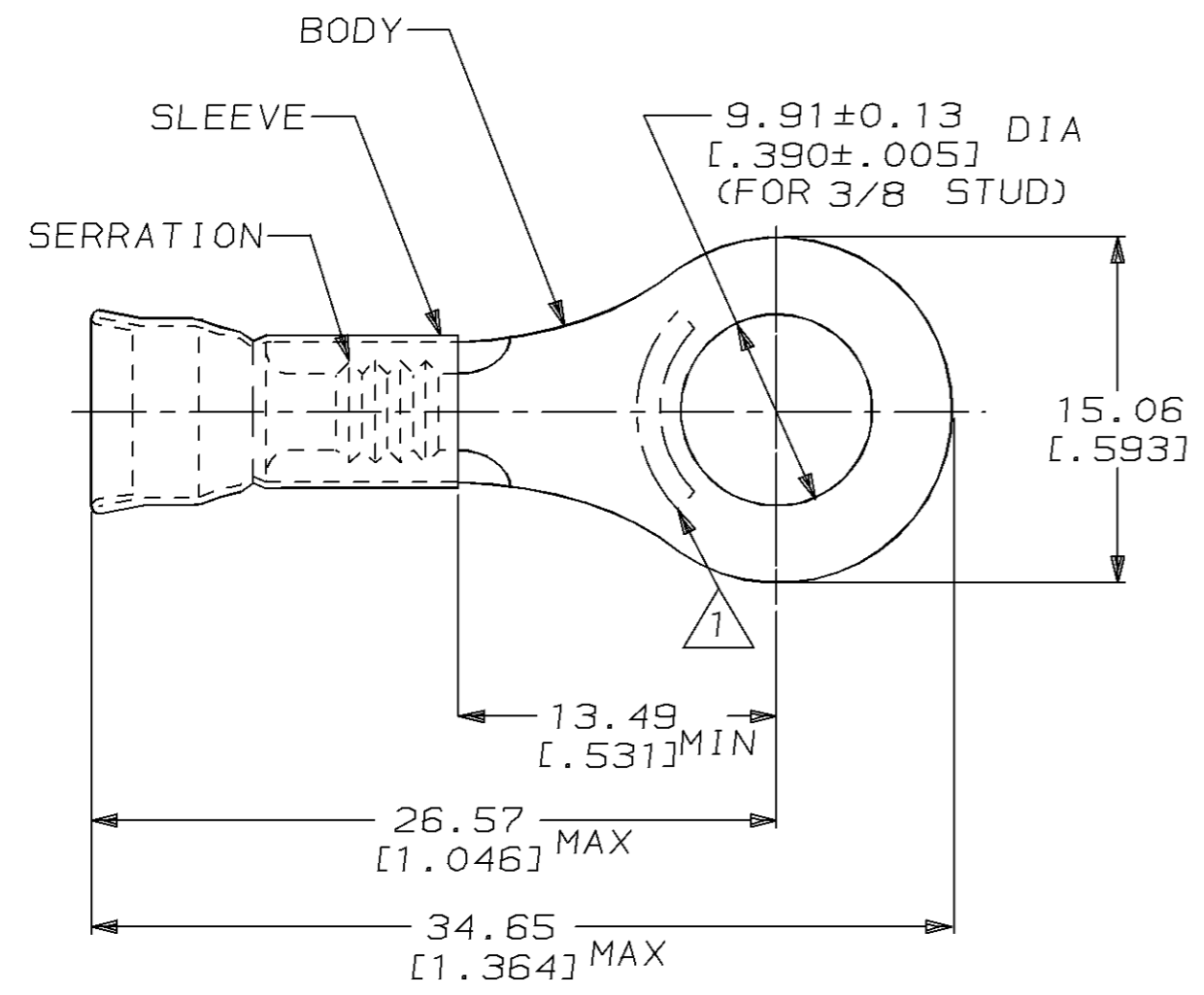

1. STAMP AMP 12-10* LOCATE APPROX AS SHOWN

- 2. WIRE INSUL DIA, 3.81-5.84 [.150-.230]
- 3. TONGUE MATL THK, 1.02±0.05 [.040±.002]

| | | |
|-----|--------------|---------|
| - | - | - |
| 500 | LOOSE PIECE | 31828 |
| QTY | PACKAGE TYPE | PART NO |

| | | | | | | |
|--|--|---|---|--|--|--|
| AMP INCORPORATED CUSTOMER SERVICE SYSTEM | | MAX RECOMMENDED OPERATING TEMPERATURE: 170°C [338°F] | THIS DRAWING IS A CONTROLLED DOCUMENT FOR AMP INCORPORATED. IT IS SUBJECT TO CHANGE AND THE CONTROLLING ENGINEERING ORGANIZATION SHOULD BE CONTACTED FOR THE LATEST REVISION. | | DWN L OLMEDA 23JAN95 | AMP AMP Incorporated Harrisburg, PA 17105-3608 |
| FOR ADDITIONAL PRODUCT INFORMATION OR COPIES OF DRAWINGS AND TECHNICAL DOCUMENTS | PRODUCT INFORMATION CENTER 1-800-522-6752 | | DIMENSIONS: mm [in] | TOLERANCES UNLESS OTHERWISE SPECIFIED: | CHK M ELLIS 23JAN95 | |
| FOR APPLICATION TOOLING INFORMATION | TOOLING ASSISTANCE CENTER 1-800-722-1111 | VOLTAGE RATING: - | | 0 PLC ±- | PRODUCT SPEC UL486A | SIZE A3 |
| FOR ORDER ENTRY | 1-800-526-5142 | CIRCULAR MIL AREA: 2.62mm²-6.64mm² [5180-13100] | | 1 PLC ±- | 2 PLC ±0.20 [0.008] | APPLICATION SPEC - |
| | | | MATERIAL BODY, CU, SLV, CU PER ASTM B152 | 4 PLC ±- | FINISH TIN PLATE PER MIL-T-10727 | DRAWING NO C-31828 |
| | | | | ANGLES ±- | WEIGHT - | SCALE 4:1 |
| | | | | | CUSTOMER DRAWING | SHEET 1 OF 1 |
| | | | | | | REV C |